



# 4JH Series - 45 / 57

Configuration	In-line, 4-stroke, vertical, water-cooled diesel engine	
Max. output at crankshaft*	33.1 kW@3000 rpm	[45 mhp@3000 rpm]
	41.9 kW@3000 rpm	[57 mhp@3000 rpm]
No. of cylinders	4 cylinder	
Displacement	2.190 L	[134 cu in]
Bore x stroke	88 mm x 90 mm	[3.46 in x 3.54 in]
Aspiration	Natural	
Combustion system	Direct injection, Bosch common rail system	
Starting system	Electric starting 12V - 1.4 kW	
Engine management	Electronic	
Cooling system	Fresh water cooling by centrifugal fresh water pump	
	Seawater cooling by rubber impeller seawater pump	
Alternator	12V - 125A	
Lubrication system	Enclosed, forced lubricating system	
Engine lube oil specifications	API class: CD or higher, SAE grade: 10W-30 or 15W-40	
Direction of rotation at crankshaft	Counterclockwise (CCW) viewed from stern	
Dry weight without gear	220 kg	[485 lbs]
Engine dimensions† L x W x H	870 x 589 x 627 mm	
Emission compliance	EU: RCD 2, BSO II, EMC	US: EPA Tier 3, EPA-C
Flywheel housing size	SAE #5	
Controls	Mechanical (optional - VC20 system)	

NOTE: Fuel condition: Density at 15°C = 0.84 g/cm³; 1 kW = 1.3596 mhp = 1.3410 HP  
 Technical data is according to (ISO 8665) / (ISO 3046)

\* Fuel temperature 40°C at the inlet of the fuel injection pump (ISO 8665)

†Length includes KM35P marine gear (Dimensions may vary with other gears/elbow)

## DIMENSIONS

**Rear view**

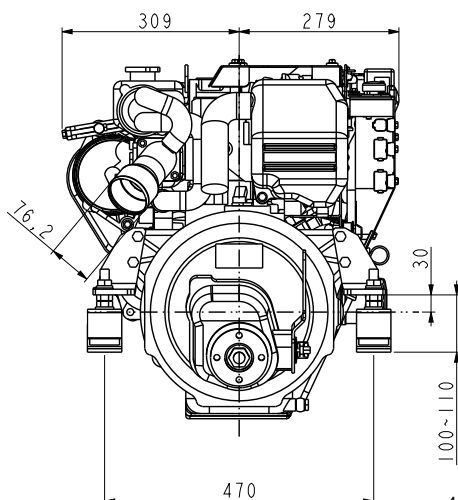

**Right side view**

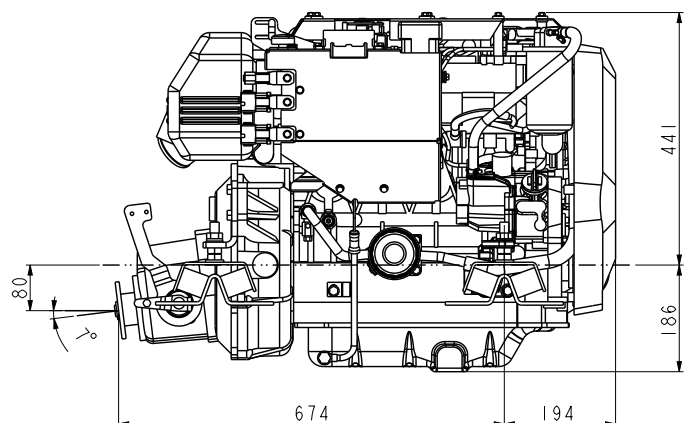

4JH45/57 with KM4A1 marine gear  
 (Not to be used for engine installation)



PERFORMANCE CURVES

**4JH45 Torque curve**

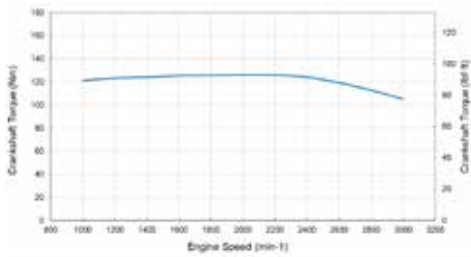

**4JH45 Output Power curve**

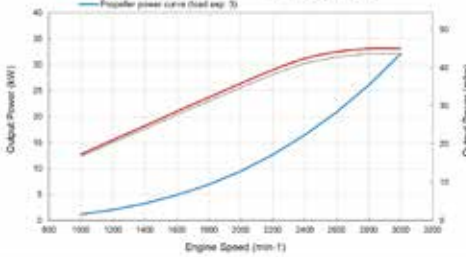

**4JH45 Fuel consumption (propload exp 3.0)**

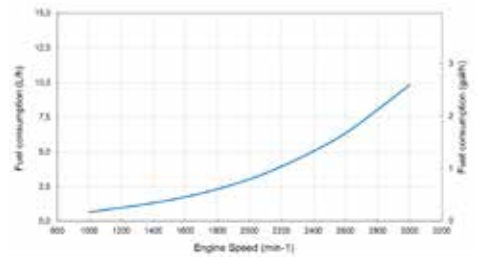

**4JH57 Torque curve**

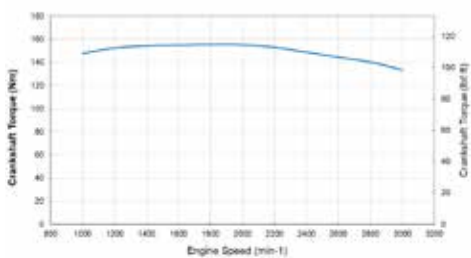

**4JH57 Output Power curve**

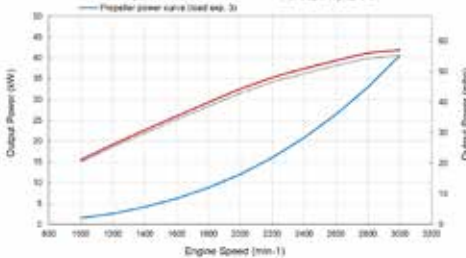

**4JH57 Fuel consumption (load exp. 3.0)**

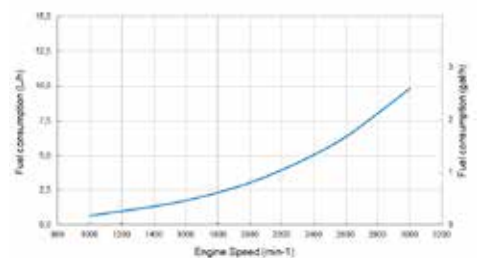

MARINE GEAR / DRIVE\*

Model	KM35P [parallel]	KM35A2 [down angle: 7°]	KM4A1 [down angle: 7°]	ZF30M [parallel]	Saildrive [SD60]
Clutch type	Mechanical cone clutch	Mechanical cone clutch	Mechanical cone clutch	Mechanical multi-disc	Mechanical multi-disc
Dry weight	15 kg [33 lbs]	16 kg [35 lbs]	33 kg [73 lbs]	23 kg [51 lbs]	44 kg [97 lbs]
Reduction ratio [fwd/asn]	2.36/3.16    2.61/3.16	2.33/3.04    2.64/3.04	1.47/1.47    2.14/2.14    2.63/2.63	2.15/2.64    2.70/2.64	2.23/2.23    2.49/2.49
Direction of rotation [viewed from stern]	Clockwise	Clockwise	Clockwise & counterclockwise	Clockwise	Clockwise & counter clockwise
Lubrication system	Splash lubrication			Trochoid pump	Splash lubrication
Lube oil specifications	API class: CD or higher, SAE grade: #20 or #30			ATF	API class: CD or higher, SAE grade: 15W-40
Max. lube oil capacity	1.1 L	0.65 L	2.0 L	1.1 L	2.8 L
Dry weight - engine & gear	235 kg [518 lbs]	236 kg [520 lbs]	253 kg [558 lbs]	243 kg [536 lbs]	264 kg [582 lbs]

\* Other marine gearboxes and configurations available upon request. Contact your local supplier for more information.

ACCESSORIES

**Standard engine package**

- Exhaust mixing elbow [L-type]
- Alternator 12V - 125A
- B25 panel
- Flexible mounts
- Mechanical throttle sensor
- Fuel pre-filter with water separator
- Fresh water expansion tank
- Belt safety cover

**Optional**

- High-riser mixing elbow [instead of L-elbow]
- Secondary alternator 12V - 125A or 24V - 60A
- C35 panel
- Extension harness [3m, 5m, 10m]
- Second station
- TFX Sidemount control head
- VC20 Vessel Control System
- NMEA2000 Engine monitoring system

- Semi 2-pole
- SOLAS including Certificate [factory fit only]
- Hot water kit with cocks
- Extension saildrive leg [75 mm]
- Propeller cone nut kit SD60
- On-board spare parts kit

NOTE: All data subject to change without notice. Text and illustrations are not binding.